



# Zignago Vetro



Zignago Vetro





Being a national and international leading company for over fifty years in the field of high quality glass packaging, Zignago Vetro SpA produces, in the two glassworks situated near Florence and Venice, over one and a half billion containers a year, which are directed to the Food & Beverage as well as to the Cosmetics & Perfumery markets.

Experience and deep knowledge of the glass manufacturing art, together with a constant renewing and anticipation of emerging trends, make Zignago's offer be the right match between a classical style and an original one and between reliability and innovation.

Its wide range for the Cosmetics & Perfumery includes containers for nail polish and for skin care, cream jars and perfume bottles.

Besides the realisation of private projects, Zignago Vetro is specialized in the research and development of standard products which are always available and ready to be customized according to customers' needs. The service is completed by the latest lacquering and printing solutions and by high quality accessories.

Zignago Vetro Group has been growing since 2002 thanks to the acquisition of Verreries Brosse SAS, premier French leading company in the production of high quality perfume bottles and of Huta Szkla Czechy in 2011, Polish glass factory, which offers a wide range of standard and customized containers for the Food & Beverage and for the Perfumery mass market.

Protagonista da oltre cinquant'anni del mercato nazionale e internazionale del packaging in vetro di alta qualità, Zignago Vetro SpA produce, nei suoi siti produttivi situati in prossimità di Firenze e Venezia, oltre un miliardo e mezzo di contenitori l'anno destinati ai settori delle Bevande & Alimenti e della Cosmetica & Profumeria.

L'esperienza e la profonda conoscenza dell'arte vetraria, il continuo rinnovamento e l'anticipazione delle nuove tendenze fanno sì che la proposta di Zignago sia la giusta coniugazione tra classicità e originalità, tra affidabilità ed innovazione.

La vasta offerta di contenitori per Cosmetica & Profumeria comprende flaconi per smalto, per la cura della pelle, vasetti per creme e flaconi per la profumeria.

Oltre allo sviluppo di progetti privati, Zignago Vetro propone un' ampia gamma di prodotti standard, sempre disponibili a magazzino e personalizzabili con le più innovative soluzioni di laccatura e serigrafia. La fornitura di accessori di alta qualità completa il servizio.

Nel 2002 il Gruppo Zignago Vetro si è ampliato con l'acquisizione della Verreries Brosse SAS, società francese leader nella produzione di flaconi e bottiglie di lusso per i mercati della profumeria e distilleria. Dal 2011 è venuta a far parte del Gruppo la Huta Szkla Czechy, società vetraria polacca specializzata nella produzione di flaconi standard e personalizzati destinati al mercato della Bevande & Alimenti e Profumeria mass market.



Eau de Toilette  
Profumi

pag. 7



Miniatures  
Miniature

pag. 39

Eau de Toilette





Durer 50



Durer 100

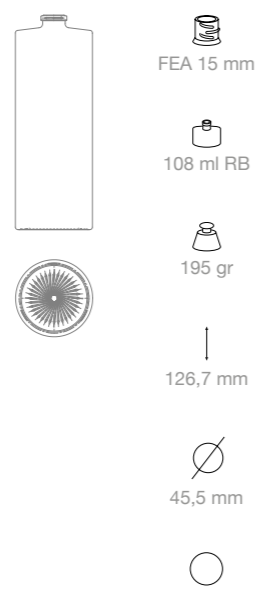

Durer 100 rigato

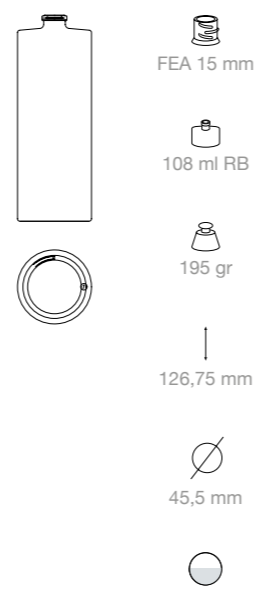

Bas 30

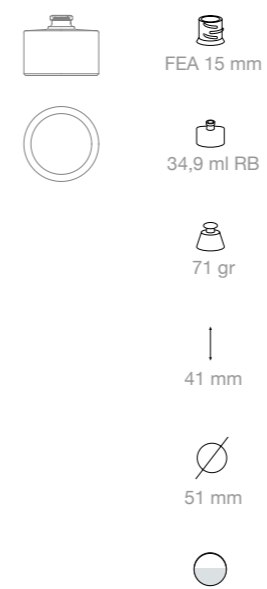

Millet 30

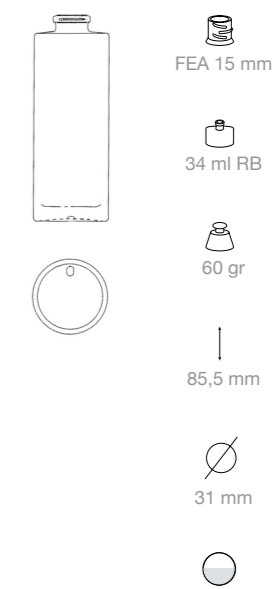





Ticino 27

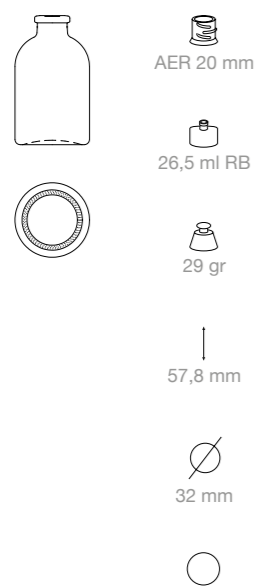

Ticino 50

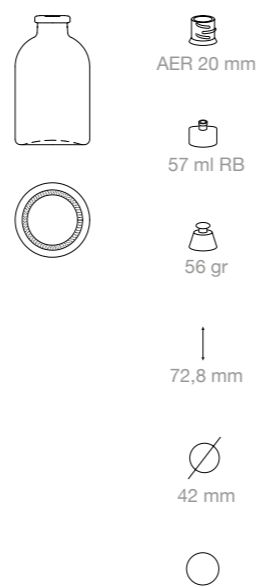

Rubens 30

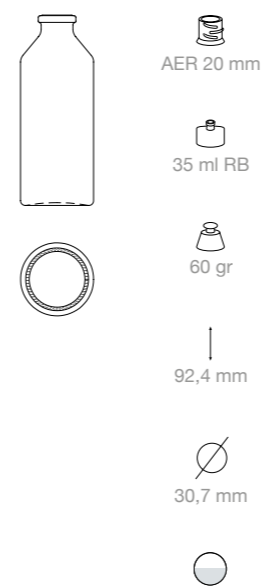

Rubens 60

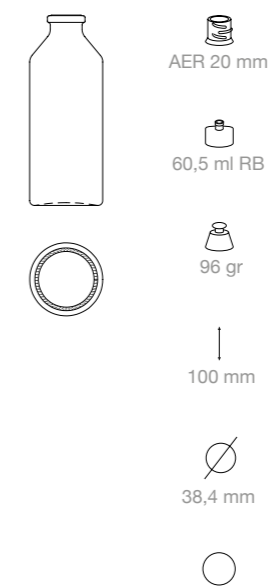

Boston Round 100

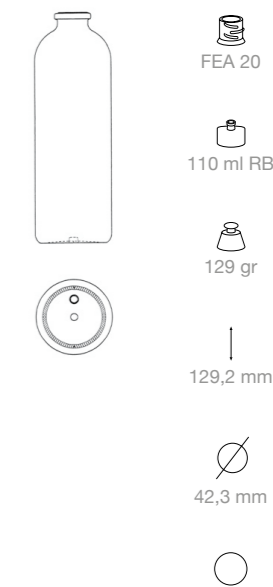



Dive 100



Lakes 100



Van Dick 50

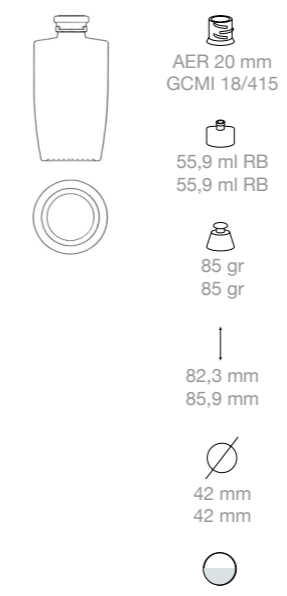

Van Dick 100

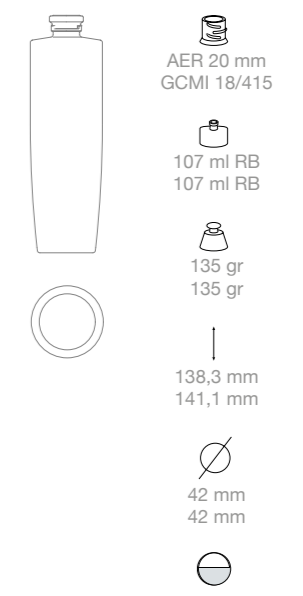





Dalì 30

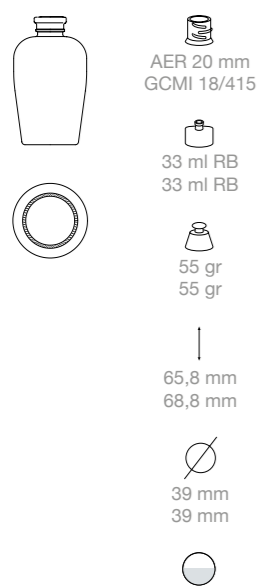

Dalì 50

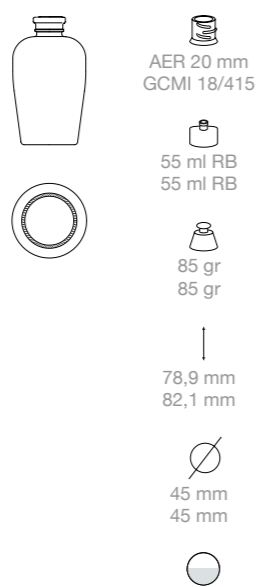

Dalì 100



Sphere 75



Gros 100

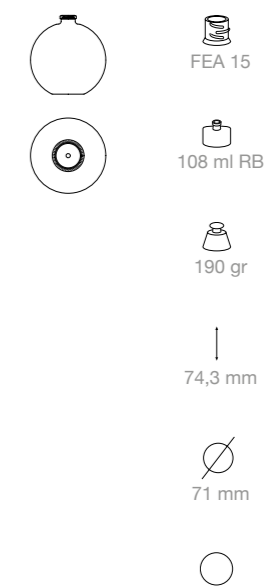



Arp 30



Arp 50

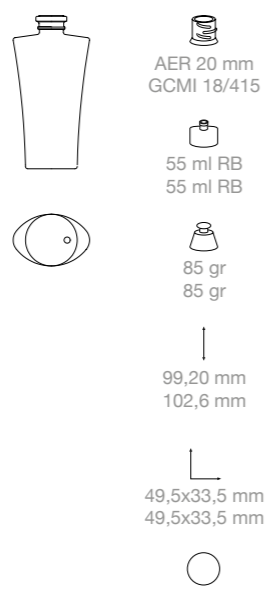

Arp 100

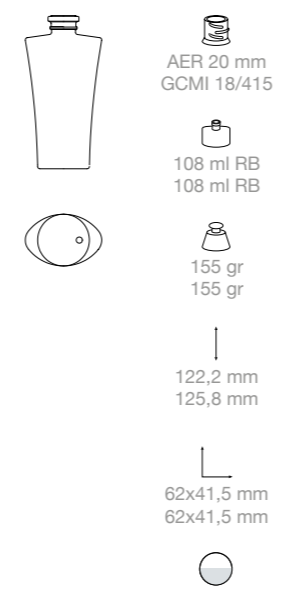

Goya 30

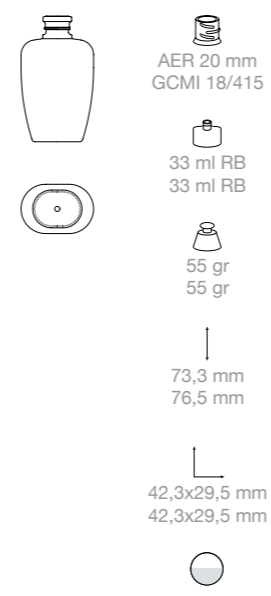

Goya 50

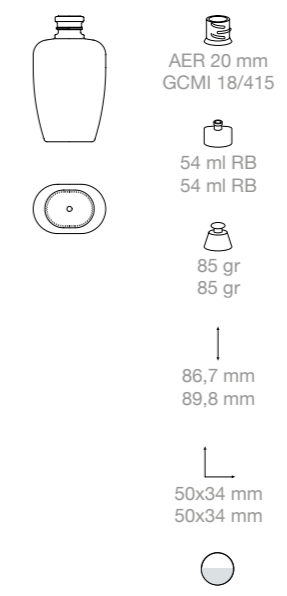

Goya 100

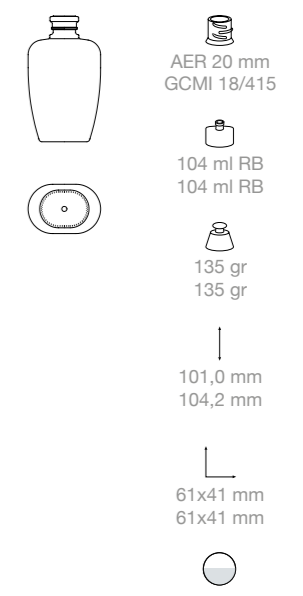



Botero 100

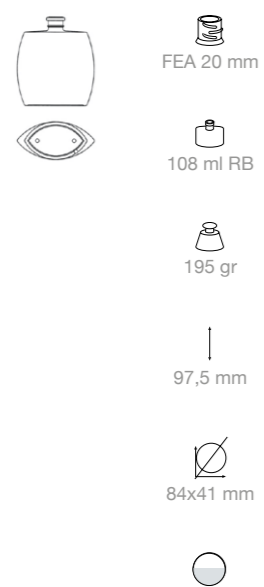

Boccioni 100



Viviani 50

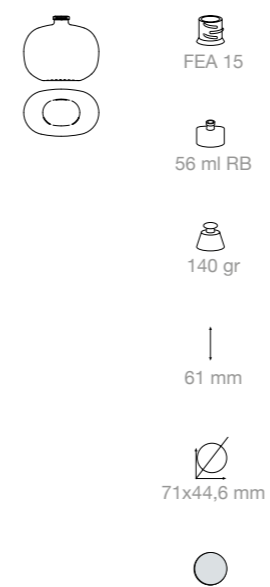

Viviani 100

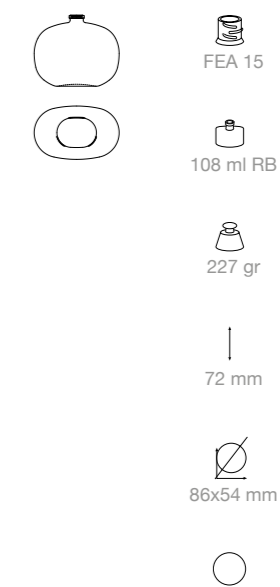



Leger 100

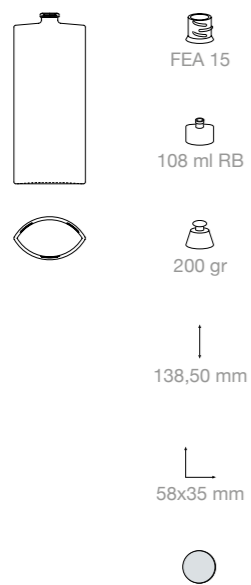

Blake 100

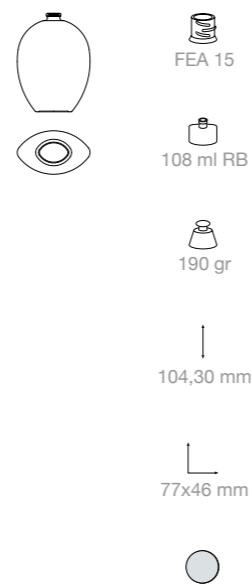

Bosch 50

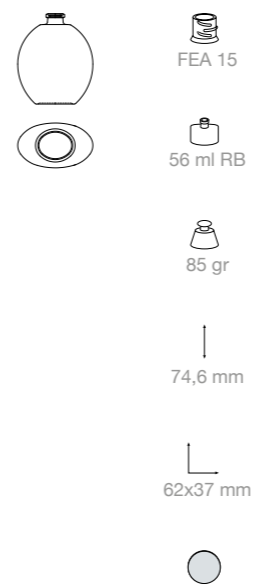

Bosch 100





Cute 75

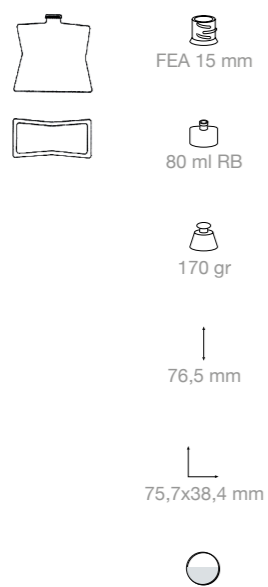

Constable 100

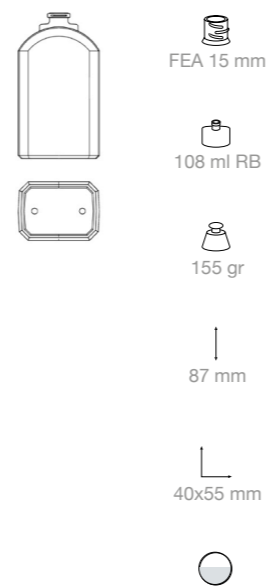

Whistler 100

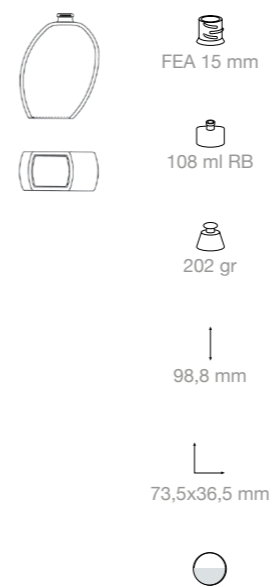

Pollock 100

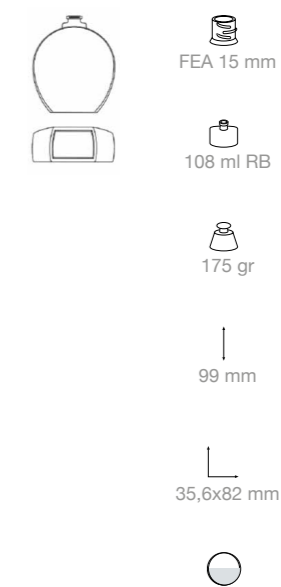



Tao 50

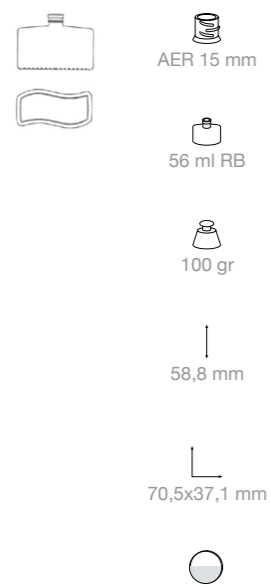

Tao 100

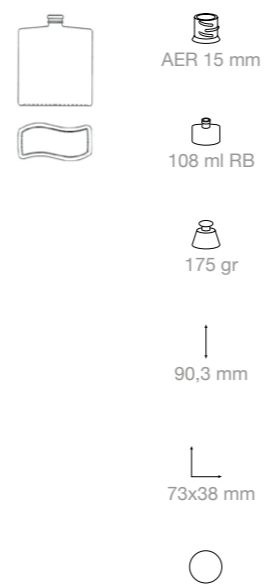

Rembrandt 100

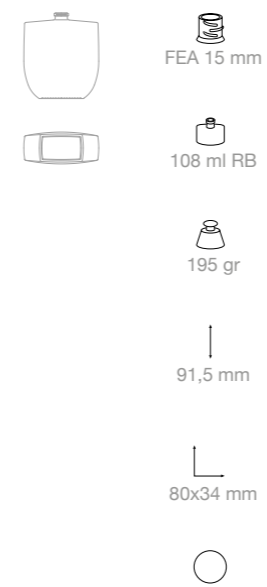

Bramante 100

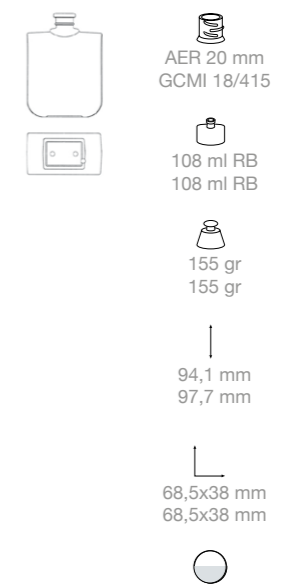





Poussin 75

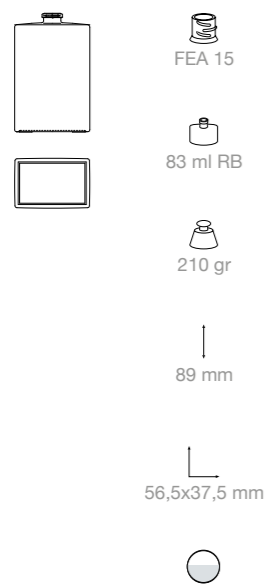

Carrier 100

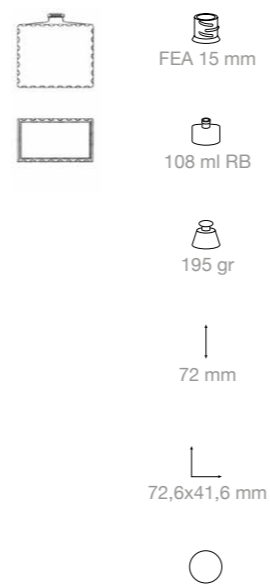

David 50

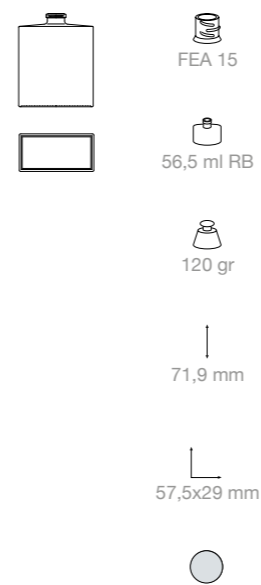

David 100

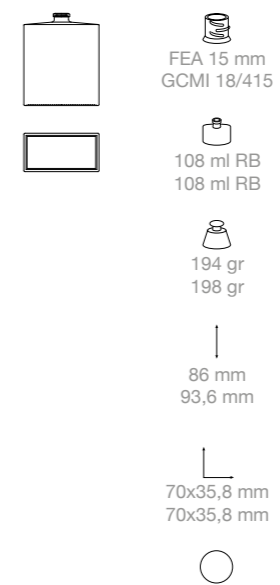

David Diamond 100

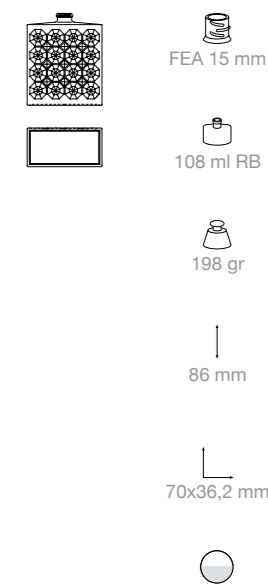





Signac 50

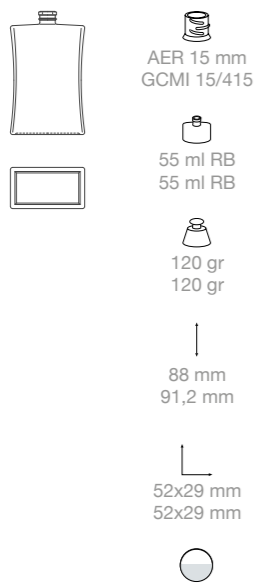

Signac 100



Vlaminck 50

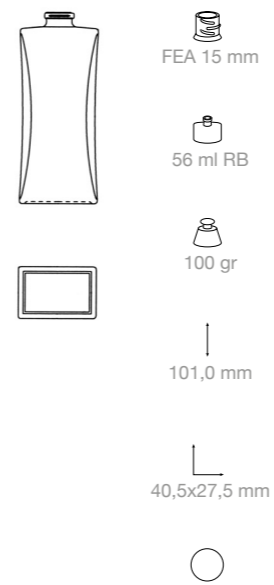

Vlaminck 100

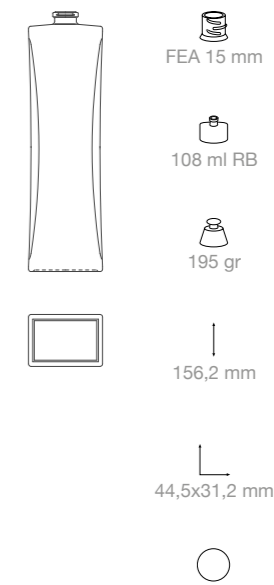



Duchamp 30

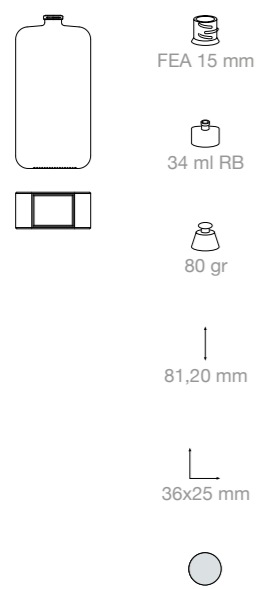

Duchamp 50

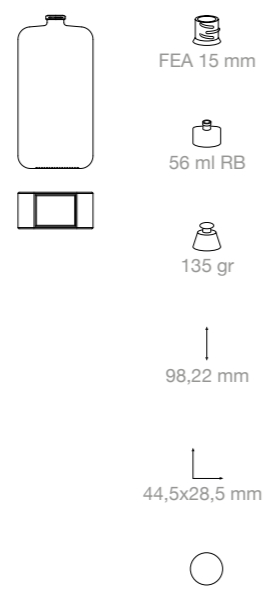

Duchamp 100

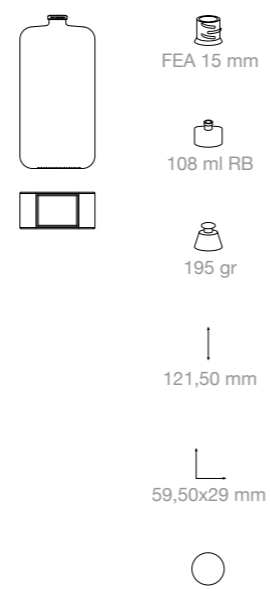

Morisot 30

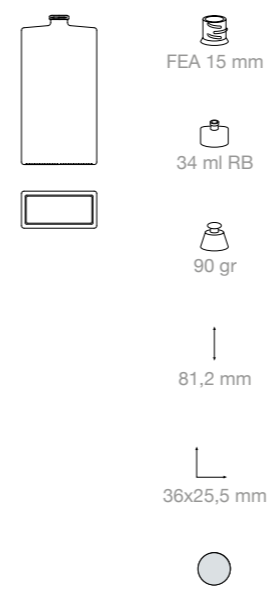

Morisot 50

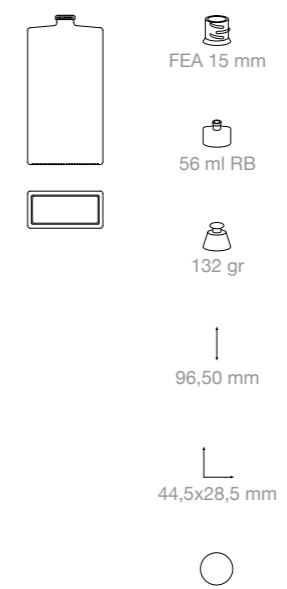

Morisot 100

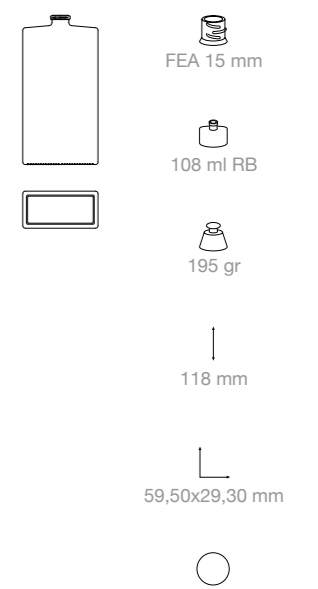



Pecos 30

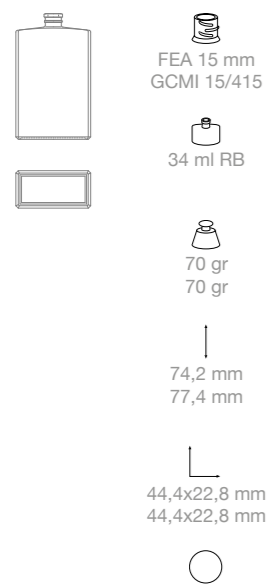

Pecos 50



Pecos 100

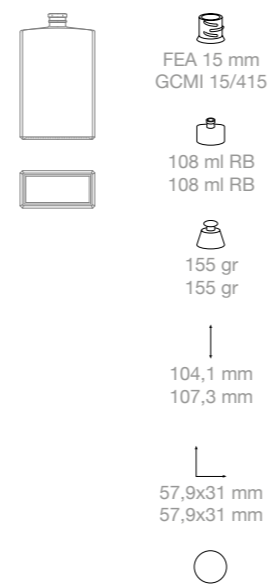

Seurat 30

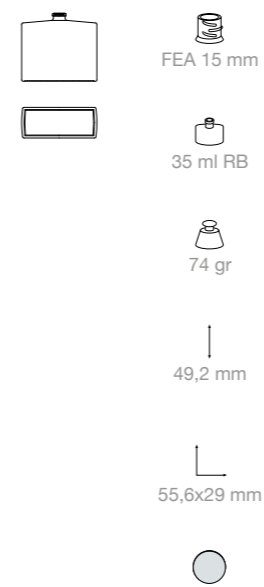

Seurat 50

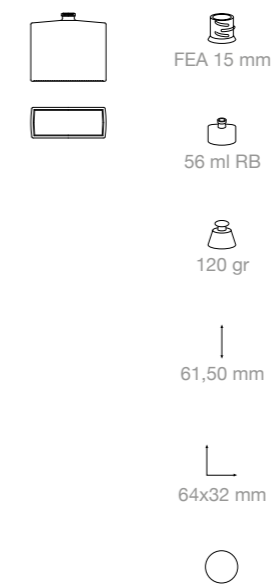

Seurat 100

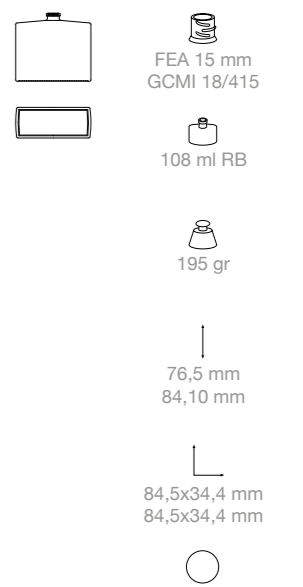



Delacroix 50

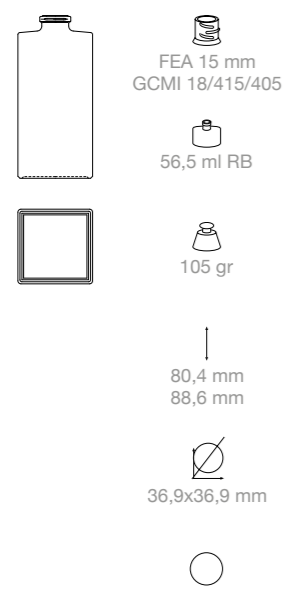

Delacroix 100

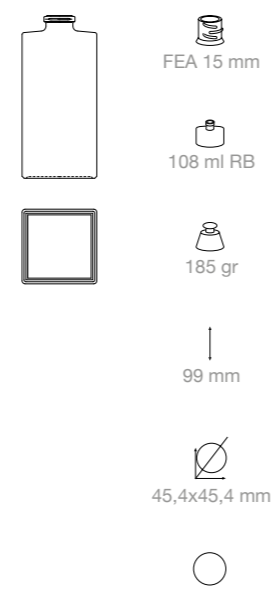

Klee 15

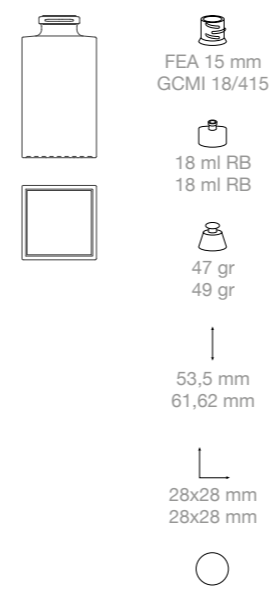

Klee 30

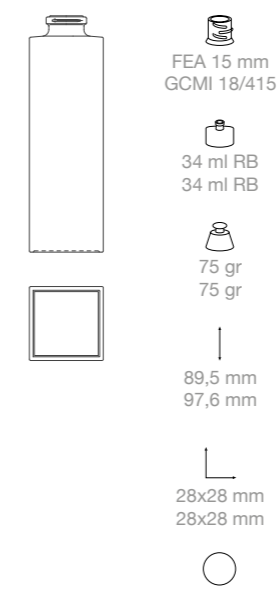

Klee 50

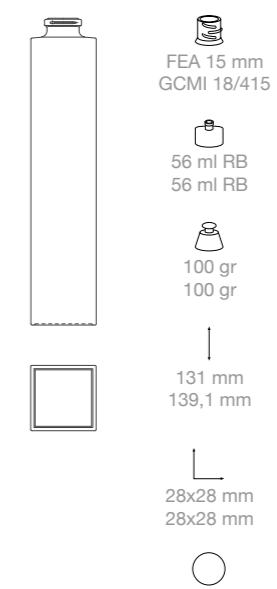

Klee 100

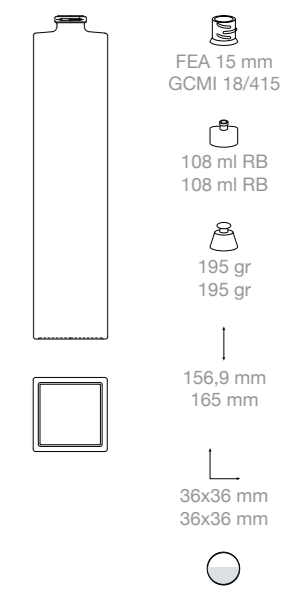



### Picasso 50

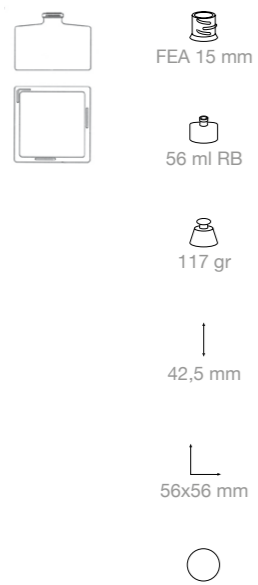

### Picasso 100

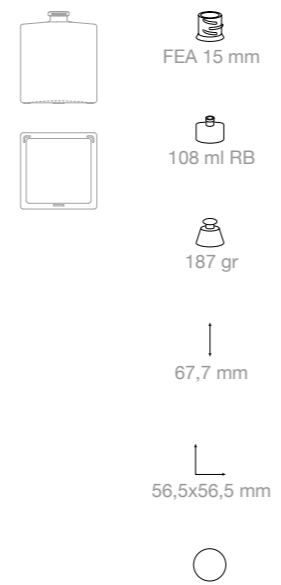

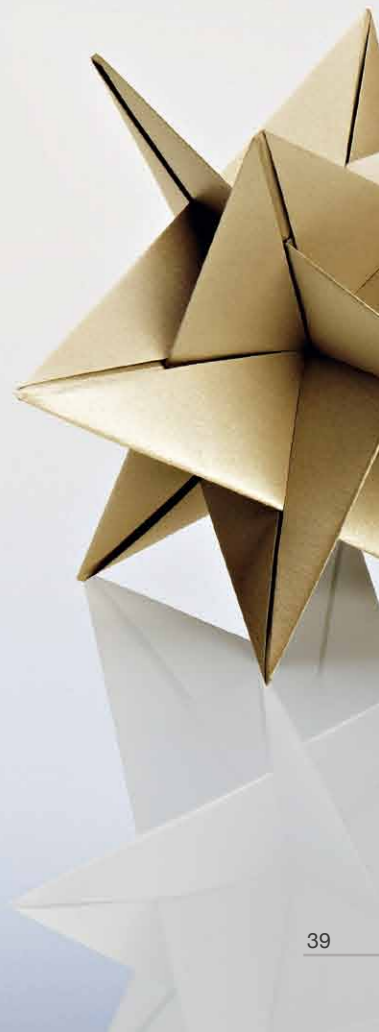



Canova 5



Mirò

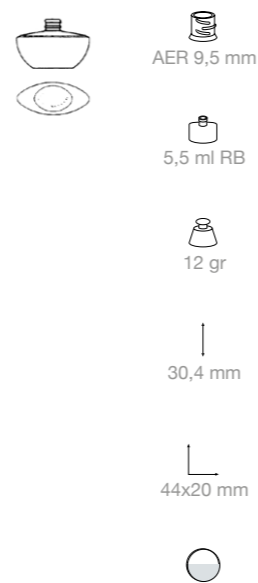

Goya 6,5

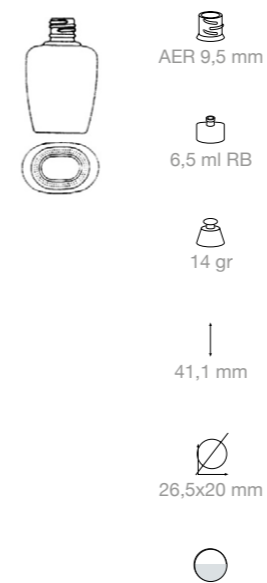

Degas

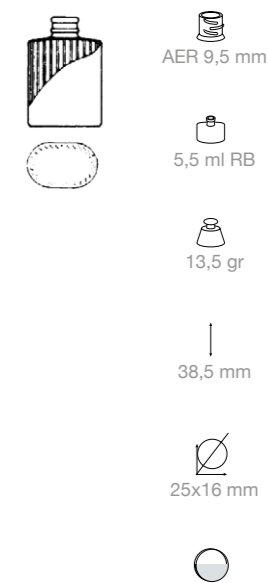











## PRODUCTS INDEX INDICE PRODOTTI

Arp 30	pag. 16
Arp 50	pag. 16
Arp 100	pag. 16
Bas 30	pag. 9
Blake 100	pag. 20
Boccioni 100	pag. 18
Bosch 50	pag. 21
Bosch 100	pag. 21
Boston Round 100	pag. 11
Botero 100	pag. 18
Bramante 100	pag. 25
Canova 5	pag. 40
Carrier 100	pag. 26
Constable 100	pag. 22
Cute 75	pag. 22
Dali 30	pag. 14
Dali 50	pag. 14
Dali 100	pag. 14
David 50	pag. 27
David 100	pag. 27
David Diamond 100	pag. 27
Degas	pag. 41
Delacroix 50	pag. 34
Delacroix 100	pag. 34
Dive 100	pag. 12
Duchamp 30	pag. 30
Duchamp 50	pag. 30
Duchamp 100	pag. 30
Durer 50	pag. 8
Durer 100	pag. 8
Durer 100 rigato	pag. 8
Goya 6,5	pag. 41
Goya 30	pag. 17
Goya 50	pag. 17
Goya 100	pag. 17
Gros 100	pag. 15
Klee 15	pag. 35
Klee 30	pag. 35
Klee 50	pag. 35
Klee 100	pag. 35
Lakes 100	pag. 12
Leger 100	pag. 20
Millet 30	pag. 9
Mirò	pag. 40
Morisot 30	pag. 31
Morisot 50	pag. 31
Morisot 100	pag. 31
Pecos 30	pag. 32
Pecos 50	pag. 32
Pecos 100	pag. 32
Picasso 50	pag. 36
Picasso 100	pag. 36
Pollock 100	pag. 23
Poussin 75	pag. 26
Rembrandt 100	pag. 25
Rubens 30	pag. 11
Rubens 60	pag. 11
Seurat 30	pag. 33
Seurat 50	pag. 33
Seurat 100	pag. 33
Signac 50	pag. 28
Signac 100	pag. 28
Sphere 75	pag. 15
Tao 50	pag. 24
Tao 100	pag. 24
Ticino 27	pag. 10
Ticino 50	pag. 10
Van Dick 50	pag. 13
Van Dick 100	pag. 13
Viviani 50	pag. 19
Viviani 100	pag. 19
Vlaminck 50	pag. 29
Vlaminck 100	pag. 29
Whistler 100	pag. 23

## LEGEND LEGENDA

-  **Type of finish**  
Tipo di imboccatura
-  **Capacity**  
Capacità
-  **Glass weight**  
Peso vetro
-  **Total height**  
Altezza totale
-  **Maximum diameter**  
Diametro massimo
-  **Item normally available**  
Articolo normalmente disponibile
-  **Item available in scheduled periods of time**  
Articolo normalmente disponibile in periodi programmati
-  **Item available only on order and for minimum quantities**  
Articolo disponibile solo su ordinazione e per quantitativi minimi

## GENERAL NOTES NOTE GENERALI

All dimensions and capacities shown in this catalogue are approximate and within tolerances stated in the technical drawings. We reserve the right to modify, cancel or replace any item shown in this catalogue, without prior notice.

Le dimensioni e la capacità dichiarate sono da intendersi approssimate alle tolleranze previste dai disegni tecnici. Modifiche e sostituzioni degli articoli presenti su questo catalogo possono avvenire senza nessun preavviso





ZIGNAGO VETRO SPA  
via Ita Marzotto 8, 30025 Fossalta di Portogruaro (VE), Italy  
tel: +39 0421 246111 / fax : +39 0421 246401  
www.zignagovetro.com / e-mail: info@zignagovetro.com

ZIGNAGO VETRO GROUP in USA  
West coast : Tel. 925-756-7471 / e-mail: lb@zignagovetrogroup.com  
East coast : Tel. 908-635-1161 / e-mail: db@zignagovetrogroup.com